

XTAR 26650 6000mAh Li-ion Rechargeable Battery

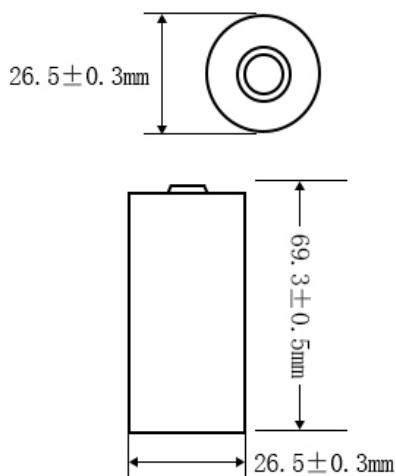

Standard Dimensions



Specifications

Nominal Capacity:	6000mAh
Mini Capacity:	5850mAh
Nominal Voltage:	3.6V
Discharge cutoff voltage:	2.5V
Max Continuous Discharge Current:	10A
Internal Resistance:	≤ 45mΩ
Cycle Life:	500+
Standard Charging Voltage:	5V
Standard Charging Current:	1200mA
Max Charging Current:	4200mA
Discharge Overcurrent Protection:	11~15A
Transport Voltage:	3.6~3.85V
Protected:	Yes
Positive Pole:	Big Button Top
Operating Temperature:	-20 to 60°C
Storage Temperature:	-20 to 50°C (best 25±5°C)
Net Weight:	≤ 100g

Name	XTAR 3.6V 26650 6000mAh Li-ion Rechargeable Battery				
Test Condition	Tests are carried out under the temperature of 20±5°C				
Test Current(A)	1.2	3	6	8.5	10
Measured Capacity (mAh)	6249	6180	6218	6206	6176
Measured Energy (Wh)	22.9	22.1	21.3	20.5	20.0

Milliamp-Hours Capacity

Constant Current Discharge to 2.5 Volts

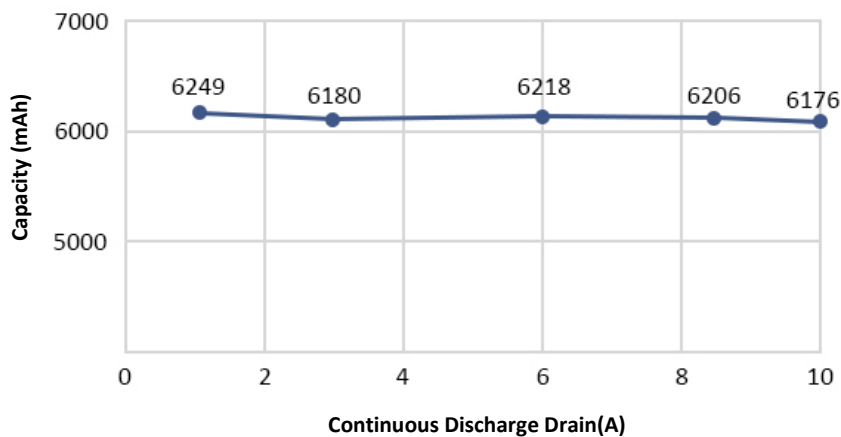

Discharge Profile

Constant Current Discharge

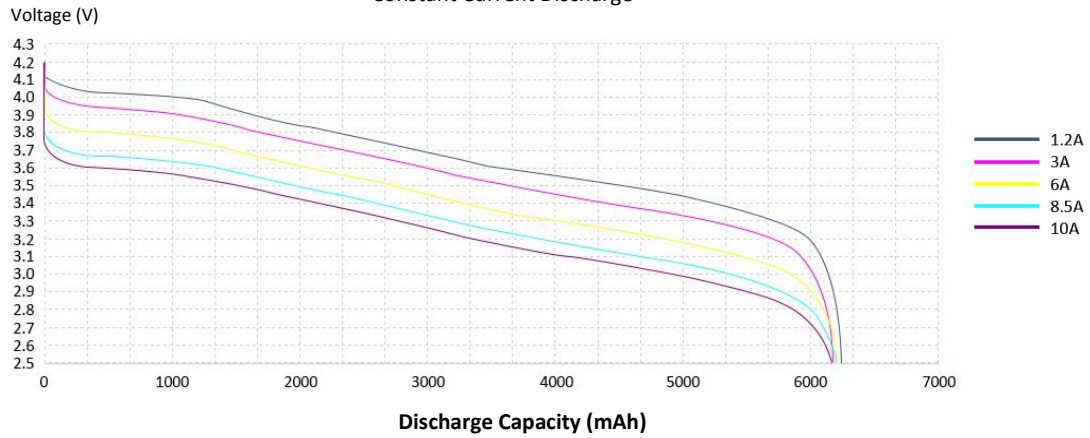

Constant Output Performance

Typical Discharge Characteristics (20±5°C)

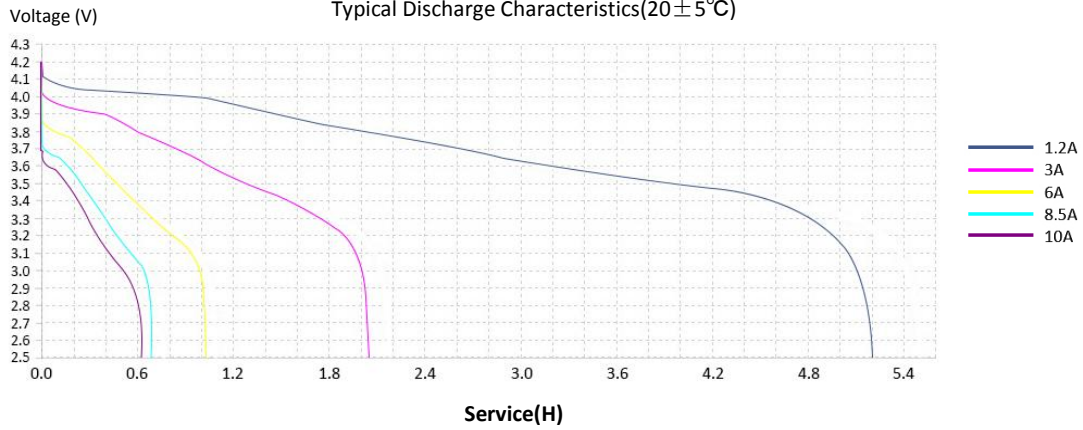

Charging Current Diagram

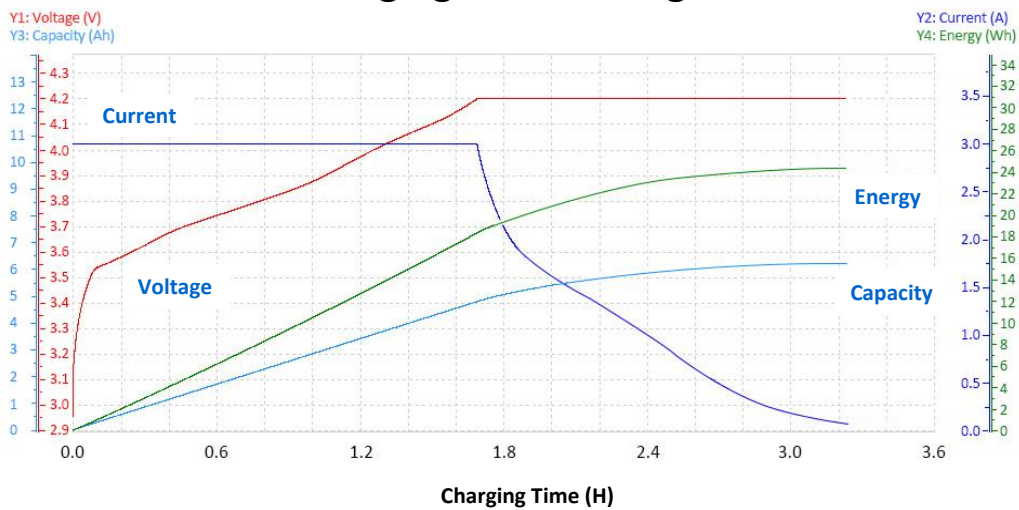

Important Notice

This data sheet contains typical information specific to batteries manufactured at the time of its publication.

Contents herein do not constitute a warranty.

©XTAR - All Rights Reserved