

鋅錳干電池規格書
SPECIFICATIONS
FOR ZINC CHLORIDE DRY BATTERY

SUM4/EXTRA

(高功率 EXTRA HEAVY DUTY)

(無添加 Pb No Lead Added)

接收人 RECEIVED BY :

制作人 Prepared by



核準人 Approved by

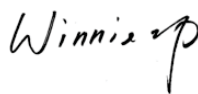

日期 Date : JAN 2022

松柏電池廠有限公司
CHUNG PAK BATTERY WORKS LIMITED
香港寫字樓:香港九龍油塘灣草園街四號華順工業大廈二樓 B 室
Unit B, 2/F., Wah Shun Industrial Building, 4 Cho Yuen Street, Yau Tong Bay,
Kowloon, Hong Kong
電話 TEL : (852) 27171338 傳真 FAX: (852) 27727727
電子郵件 E-MAIL: cpgsales@chungpak.com 網址 Website: www.vinnic.com

松柏(廣東)電池工業有限公司
CHUNG PAK (GUANG DONG) BATTERY INDUSTRIAL CO.,LTD
廠址: 中國廣東省佛山市順德區陳村鎮佛陳公路紺村路段
Gan Cun Section, Fo Chen Road, Chen Cun County, Shun De District, Fo Shan City, Guang Dong
Province, China
電話 TEL: (86 757) 23312338 傳真 FAX: (86 757) 23312339
電子郵件 E-MAIL: cpgsales@chungpak.com 網址 Website: www.vinnic.com

本公司保留更改產品規格書任何資料的權力，且無須預先通知。

We reserve all rights for the change of product specification and any information without any prior notice.

鋅錳干電池 Zinc Chloride Dry Battery SUM4/EXTRA

1、範圍 Scope

該規格書適用於由松柏(廣東)電池工業有限公司提供之“Vinnic”—“銀戰士”商標無汞、無添加鉛鋅錳干電池。

This specification is applicable to the “Vinnic” brand Zinc Chloride Mercury Free and No Lead Added Dry Batteries supplied by **CHUNG PAK BATTERY WORKS, LTD.**

2、產品類型 Kind of Products Specified

Vinnic	IEC	ANSI	JIS	其他/ Others
SUM4/EXTRA	R03	24D	R03	AAA, 1212

3、規範性引用文件 Normative references

GB/T 8897.1-2021 原電池 第 1 部分：總則 (IEC 60086-1:2021, MOD);

GB/T 8897.2-2021 原電池 第 2 部分：外形尺寸和電性能要求 (IEC 60086-2:2021, MOD);

GB/T 8897.5-2013 原電池 第 5 部分：水溶液電解質電池的安全要求 (IEC 60086-5:2016, IDT);

符合 2006/66/EC(EEC)環保要求。

GB/T 8897.1-2021 Primary batteries –Part 1: General (IEC 60086-1:2021, MOD);

GB/T 8897.2-2021 Primary batteries –Part 2: Physical and electrical specifications (IEC 60086-2:2021, MOD);

GB/T 8897.5-2013 Primary batteries –Part 5: Safety of batteries with aqueous electrolyte (IEC 60086-5:2016, IDT);

Conform to Directive 2006/66/EC.

4、化學體系 Chemical System

鋅-碳/ Zinc-Carbon

5. 技術參數 Technology Parameters

No.	項目 Item	特性 Characteristics	備註 Remark
5.1	型號 Model No.	SUM4/EXTRA	
5.2	額定電壓 Nominal Voltage	1.5V	
5.3	典型容量 Nominal capacity (20±2°C)	500 mAh	以 75Ω 放電,每天 4 小時, 終止電壓 0.9V, 取 8pcs 電池的放電平均值 Discharge at 75Ω 4h/day, E.V.0.9V (The average discharging time of 8pcs batteries)
5.4	放電時間 Typical Discharge Duration (20±2°C)	85 min	以 5.1Ω 放電,每天 1 小時, 終止電壓 0.8V, 取 8pcs 電池的放電平均值 Discharge at 5.1Ω 1h/day, E.V.0.8V (The average discharging time of 8pcs batteries)
		29 hrs	以 75Ω 放電,每天 4 小時, 終止電壓 0.9V, 取 8pcs 電池的放電平均值 Discharge at 75Ω 4h/day, E.V.0.9V (The average discharging time of 8pcs batteries)
5.5	保存能力 Retention	90%	(於 20°C 條件下存放 12 個月) After 12 months storage (20°C)
		85%	(於 20°C 條件下存放 24 個月) After 24 months storage (20°C)
		75%	(於 20°C 條件下存放 36 個月) After 36 months storage (20°C)

鋅錳干電池 Zinc Chloride Dry Battery SUM4/EXTRA

(續上表 Continuous)

5.6	規格尺寸 Dimension	直徑 Diameter (Ø)	10.5mm
		高度 Height (H)	44.5mm
5.7	重量(大約) Weight (approx)	9.2g	
5.8	使用溫度 Operating Temperature	0°C ~ 40°C	
5.9	貯存溫度範圍 Storage Temperature	20±5°C	

5.10 成品電池結構圖 The Drawing of The Finished Battery :

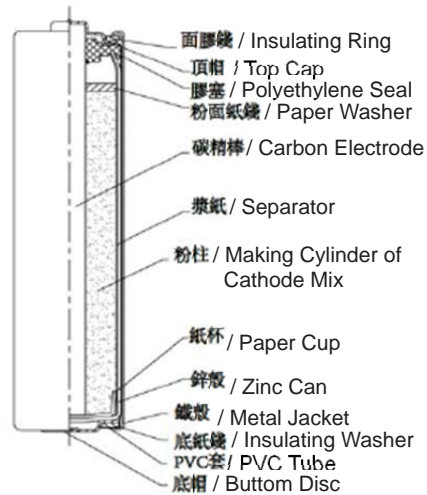

5.11 外形尺寸與端子 Outside shape dimensions and terminals:

鋅錳干電池規格尺寸 Dimensions of Zinc Chloride Dry Battery		R03	
	單位 Unit: mm		
		Max.	Min.
A	44.5		
B		43.5	
C		4.3	
E	0.5		
F	3.8		
G		0.8	
Ø	10.5	9.8	

註 Remarks:

- A: 電池總高 Overall height of battery
- B: 接觸端子間的高度(不包括隨意點) Height between contact terminals without pip
- C: 負極端子接觸區外徑 Outer diameter of negative terminal Contact area
- E: 負極端子凹入 Depression of negative terminal from outer casing
- F: 在規定凸出高度以內的正極端子直徑 Diameter of positive terminal within The specified projection height
- G: 正極端子凸出區的高度 Height of projected area of positive terminal, exclusive part
- Ø: 電池直徑 Diameter of battery

鋅錳干電池 Zinc Chloride Dry Battery SUM4/EXTRA

6. 特性 Performance

(所有測試方法見附錄 1 For all test method, refer to Appendix 1)

6.1 空載電壓 Open-circuit voltage:

初制成/ Initial	1.600 ~ 1.720 V
貯存 12 個月後 After 12 months storage	1.530 ~ 1.680 V
貯存 24 個月後 After 24 months storage	1.500 ~ 1.630 V
貯存 36 個月後 After 36 months storage	1.500 ~ 1.600 V

6.2 放電壽命 Service out-put:

參考要求 Reference Requirement	放電條件 Discharge Condition			最小平均放電時數 Average Minimum duration	
	負載電阻 Load resistance	放電方法 Discharge method	終止電壓(V) End point Voltage(V)	初制成 Initial	存放 12 個月后 After 12 months storage
REF	3.9Ω	24h/day	0.90 V	38 min	32 min
IEC	5.1Ω	4min/h, 8h/day	0.90 V	90 min	76 min
IEC	5.1Ω	1h/day	0.80 V	78 min	70 min
IEC	24Ω	15s/min, 8h/day	1.00 V	8.5 hrs	7.6 hrs
IEC	75Ω	4h/day	0.90 V	28 hrs	25 hrs
IEC	50mA	1h/12h, 24h/day	0.90 V	8.5 hrs	7.6 hrs
ANSI	250mA	5min/h, 12h/day	1.10 V	0.6 hrs	0.5 hrs

“初制成”是指生產後一個月或一個月以內的产品，包括那些生產後已開始放電尚不到三個月的電池。
The word“initial”is applicable to the products elapsed one month or less after production , including those , to which tests have been started in less than three month after production.

符合性標準 Satisfaction Standard:

- 1) 每批放電標準用 8 個電池作測試;
 - 2) 每個放電標準下的平均放電時間的結果等於或者大於平均最小放電時間要求;不多於一個電池的電性能輸出低於規格要求的 80%;
 - 3) 允許一次重新測試來確定先前的結果。
- 1) 8 piece of battery will be tested for each discharging standard;
 - 2) The result of the average discharging time from each discharging standard shall be equal to or more than the average minimum time requirement;and no more than one battery has a service output less than 80% of the specified requirement.
 - 3) One re-test is allowed to confirm the previous result.

鋅錳干電池 Zinc Chloride Dry Battery SUM4/EXTRA

6.3 過放抗漏液 Overdischarge electrolyte leakage resistance:
沒有變形和外部液体漏出。

No deformation and no external electrolyte leakage shall be observed.

6.4 高溫抗漏液 High temperature electrolyte leakage resistance:
沒有變形和外部液体漏出。

No deformation and no external electrolyte leakage shall be observed.

6.5 保存期：3 年。(溫度 20±2℃，相對濕度 55±20%)

Storage life: 3 years. (Temperature: 20±2℃, Relative Humidity 55±20%)

6.6 終止使用日期表示/ Expiry date representation

終止使用日期用以下印在電池底部之標注來表示

The expiry date is represented by means of the following abridged notation on the bottom of a completed battery.

例如/Example: 03-2025

(製造於 2022 年第 1 季度/ Manufactured in the First Quarter of 2022)

6.7 安全測試 Safety Test

6.7.1 指定使用的檢驗項目及要求(見表 1)

Intended use tests and requirements (appendx : 1)

檢驗項目 Test		所模擬的指定使用 Intended use simulation	要求 Requirements
電性能檢驗 Electrical test	A	電池部分使用(部分放電)后貯存 Storage after partial use	不泄漏 No leakage (NL) 不爆炸 No explosion (NE)
環境檢驗 Environmental Tests	B-1	運輸-沖擊 Transportation shock	不泄漏 No leakage (NL) 不爆炸 No explosion (NE)
	B-2	運輸-振動 Transportation vibration	不泄漏 No leakage (NL) 不爆炸 No explosion (NE)
氣候-溫度環境 Climatic-temperature	C	氣溫-溫度循環 Climatic-temperature cycling	不爆炸 No explosion (NE)

6.7.2 可預見誤用的檢驗和要求

Reasonably foreseeable misuse tests and requirements

檢驗項目 Test		所模擬的誤用 Misuse simulation	要求 Requirements
電性能檢驗 Electrical tests	D	不正確的安 Incorrect installation	不爆炸 No explosion (NE)
	E	外部短路 External short circuit	不爆炸 No explosion (NE)
	F	過放電 Overdischarge	不爆炸 No explosion (NE)
環境檢驗 Environmental test	G	自由跌落 Free fall	不爆炸 No explosion (NE)

所有 6.7 測試均參照 IEC 60086-5 和 GB 8897.5。

All of test (6.7) are meet IEC 60086-5 & GB 8897.5.

7. 重金屬含量 Content of heavy metals

電池中重金屬物質含量如下：

The following material content of heavy metals in the batteries:

Hg	Cd	Pb
<0.0001%	<0.001%	<0.004%

鋅錳干電池 Zinc Chloride Dry Battery SUM4/EXTRA

8. 商標與包裝 Brand and packaging

8.1 標準与包裝附圖 Standard and packaging

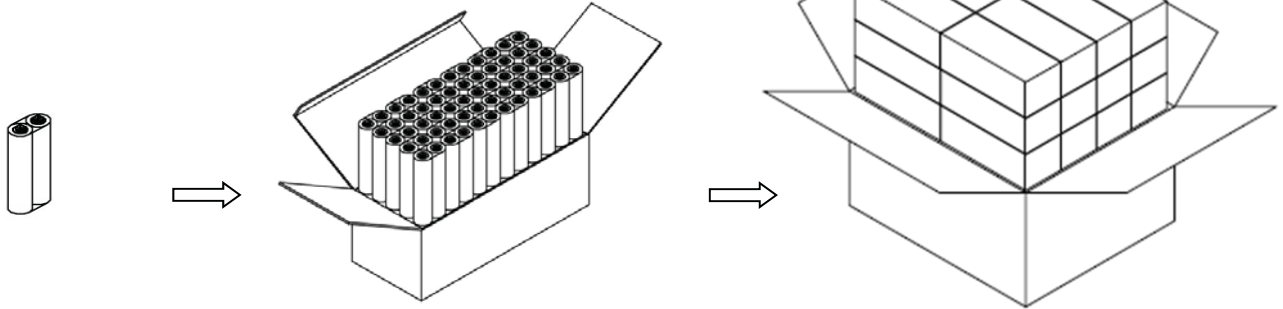

SUM4/EXTRA 2 粒裝
SUM4/EXTRA – SP2

60 粒/彩盒(Display Boxes)
彩盒尺寸(Boxes Measure):
126X52X46 mm

1440 粒/外箱(Display Carton)
外箱尺寸(Carton Measure):
260X220X146 mm

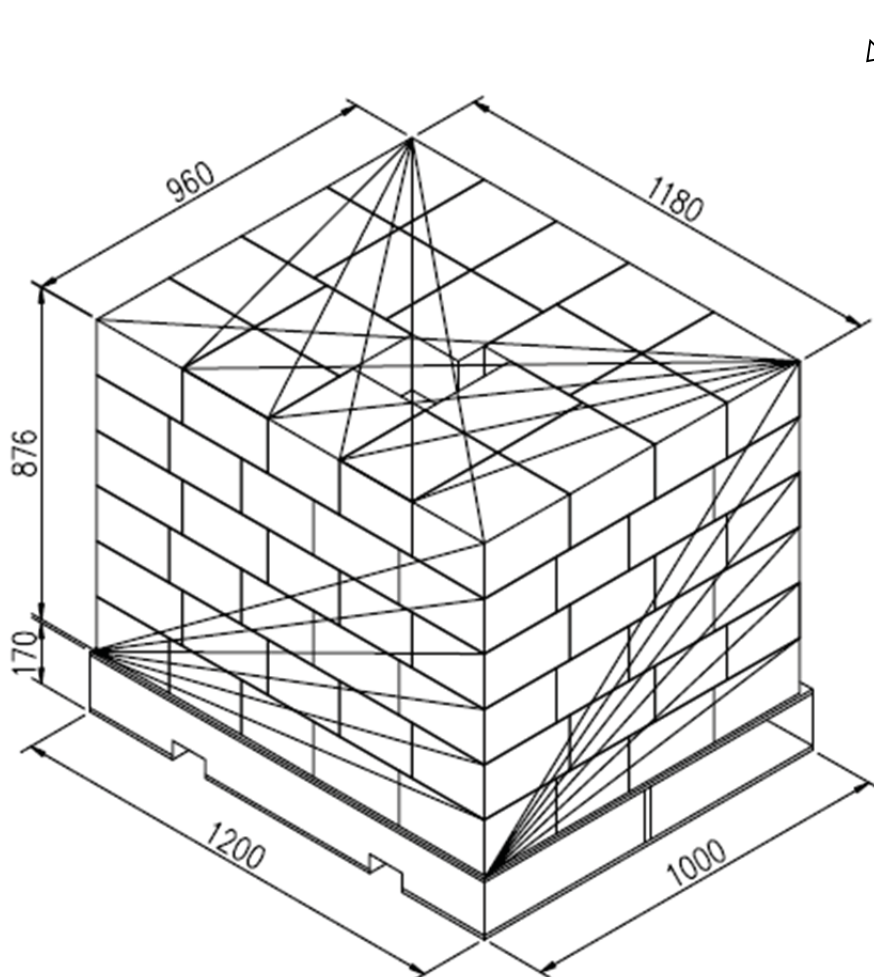

貨物尺寸 Goods Dimension:
貨物高度 Height: 876 mm
貨物長度 Length: 1180 mm
貨物寬度 Width: 960 mm

木制的卡板 Wooden Pallet:
卡板高度 Pallet Height: 160 mm
卡板尺寸 Pallet Measure: 1200X1000mm

重量 Weight:
卡板重量 Pallet Weight: 20 kgs
淨重 Net Weight: 1516 kgs
毛重 Gross Weight: 1593 kgs

數量 Quantity :
1 層=19 箱
1 Layer = 19 Cartons
6 層 X 19 箱=114 箱/卡板
6 Layer X 19 Cartons=114 Cartons / Pallet

8.2 可按客戶之要求特別安排。

Both OEM and ODM orders are welcome. Any specific design and packaging requirements will be accommodated as required.

鋅錳干電池 Zinc Chloride Dry Battery SUM4/EXTRA

9、安全指導 Safety instructions

！ 使用注意事項 Caution

- 應按電池及電器具上標明的極性標誌(+和-)正確地裝入電池。

Always insert batteries correctly with regard to the polarities (+ and -) marked on the battery and the equipment.



- 接觸電池端子使用鍍鎳鐵或鍍鎳不銹鋼。

Use Nickel-plated iron or Nickel-plated stainless steel for the terminals that contact the battery.

- 確保端子接觸壓力最小為 50g，以獲得穩定的接觸。

Make sure that terminal contact pressure is 50g minimum, for a stable contact.

- 保持電池和接觸端子表面清潔，無水分和異物。

Keep the battery and contact terminal surfaces clean and free from moisture and foreign matter.

- 插入電池前，檢查電池接觸端子是否正常，是否彎曲或損壞。(彎曲的端子可能與電池接觸不良或導致短路。)
- Before inserting the battery, check the battery contact terminals to make sure they are normal, not bent or damaged. (Bent terminals may not make good contact with the battery or may cause short circuit.)

- 當電池的正極(+)和負極(-)直接連接時，電池就可能被短路，從而有可能導致泄放、洩漏、爆炸和人身傷害。
- When the positive (+) and negative (-) terminals of a battery are in electrical contact with each other, the battery becomes short-circuited. This may result in venting, leakage, explosion and personal injury.



- 請勿混合使用不同型號和品牌的電池，或新舊電池。電池組應該用相同電壓、容量和內阻的單個電池組裝。
- Do not mix batteries of different types and brands, or new and used batteries. We are well informed that battery pack should be assembled with single batteries of similar voltage, capacity and inner resistance.



- 使用高阻抗(1M 或更高)電壓表測量電池電壓。

Do not contact terminals with conductive i.e. metal, goods. Keep batteries in non-conductive, i.e. plastic, trays.

- 請勿將端子與導電金屬、物品接觸。把電池放在不導電的托盤裡。

Reduce impact to insulation layer from vibration, but the dimension will enlarge.

鋅錳干電池 Zinc Chloride Dry Battery SUM4/EXTRA

- 電池艙尺寸應合適，不宜過松或過緊，避免振動時對電池絕緣層、絕緣件造成破壞。
Reduce impact to insulation layer from vibration, but the dimension will enlarge.
- 更換電池時，要用相同牌號，相同類型的新電池同時換掉所有的電池。
Battery characteristics vary with type and grade, even when batteries are the same size and shape.
When replacing batteries with new ones, be sure to carefully check the symbols and numbers on them.

！ 危險 Danger

- 電池應放在兒童拿不到的地方。吞食會導致化學灼傷，軟組織穿孔和死亡。萬一誤吞，應立即就醫。
Keep batteries out of the reach of children. Swallowing coin cells or batteries can cause chemical burns, perforation of soft tissue, and in severe cases can cause death. They need to be removed immediately if swallowed.



- 無成人監督時請勿讓兒童更換電池。
Do NOT allow children to replace batteries without adult supervision.
- 請勿對電池充電。試圖對不可充電的原電池充電會使電池內部產生氣體和/熱量，導致泄放、泄漏、爆炸和人身傷害。
Do NOT charge batteries. Attempting to charge a non-rechargeable (primary) battery may cause internal gas and/or heat generation resulting in venting, leakage, explosion and personal injury.



- 請勿拆卸電池。拆卸電池時與電池內的部件接觸是有害的，可能會導致人身傷害或著火。
Do NOT dismantle batteries. When a battery is dismantled or taken apart, contact with the components can be harmful and may cause personal injury or possibly fire.



- 請勿破壞電池。不要對電池擠壓、打孔或進行其他形式的破壞，可能導致泄放、泄漏、爆炸及人身傷害。
Do NOT deform batteries. Batteries should not be crushed, punctured, or otherwise mutilated. Such abuse may result in venting, leakage and explosion and cause personal injury.



鋅錳干電池 Zinc Chloride Dry Battery SUM4/EXTRA

- 請勿用火處理電池。用火處理電池時，所產生的熱量可導致電池爆炸和人身傷害。不要焚燒電池，除非被允許在可以控制的爐子進行處理。

Do NOT dispose of batteries in fire. When batteries are disposed of in fire, the heat build-up may cause explosion personal injury. Do Not incinerate batteries except for approved disposal in a controlled incinerator.



- 請勿加熱電池。電池被加熱后有可能發生泄放、泄漏和爆炸并導致人身傷害。
Do NOT heat batteries. When a battery is exposed to heat, venting, leakage and explosion may occur and cause personal injury.
- 不要過度放電電池。當電池與外部電源連接或與其他電池串聯時發生過放電，可能發生爆炸。
DO NOT over-discharge the battery. In case the battery is over-discharged when connected with exterior power source or connected with other batteries in series, explosion may occur.
- 當儲存或扔掉電池時，一定要用膠帶把它蓋上。如果電池與其他金屬物體接觸，可能會引起火災或損壞。
When storing a battery or throwing it away, be sure to cover it with tape. If the battery is contacted with other metal objects, it could cause fire or become damaged.

！警告 Warning

- 使用前請仔細閱讀使用說明書，不正確的操作可能導致泄漏、發熱、冒煙、爆炸或火災，造成設備故障或損傷。
Thoroughly read the user's manual before use, inaccurate handling may cause leakage, heat, smoke, explosion, or fire, causing device trouble or injury.
- 按電池及用電器標明的極性標誌(+和-)正確裝入電池。
Insert the battery with the “+” and “-” ends correctly oriented.
- 不要將新舊電池或不同類型或牌號的電池混用。
If the battery is used together with new batteries, do not use it with a different type battery.
- 不要直接焊接電池。
Do not solder the battery directly. Protect the welding point and connector.
- 電池最好存放在乾燥和涼爽的環境中。避免將電池存放在陽光直射的地方，或過熱潮濕的地方。為了保證電池的使用壽命，必須避免高溫儲存。
The battery should be preferably stored in dry and cool conditions. Avoid storing the battery in direct sunlight, or in excessively hot and humid place. Storage at high temperature must be avoided to preserve the battery life time.

！存放 Storage

- 電池最適宜儲存于乾燥和涼爽的環境中。
The cell should be preferably stored in dry and cool conditions.

鋅錳干電池 Zinc Chloride Dry Battery SUM4/EXTRA

附錄 1 : 測試

Appendix 1: Test

1. 樣品貯存和測試條件/ Storage and test conditions for samples

如果沒有規定，一般地，樣品貯存條件為：溫度 $20\pm 2^{\circ}\text{C}$ ，濕度 $55\pm 20\%$ 。

樣品測試條件為：溫度 $20\pm 2^{\circ}\text{C}$ ，濕度 $55\pm 20/-40\%RH$ 。

Unless otherwise specified, the storage conditions for samples shall be, as a general rule, at the temperature of $20\pm 2^{\circ}\text{C}$ and the relative humidity of $55\pm 20\%$.

And the test conditions is temperature of $20\pm 2^{\circ}\text{C}$ and the relative humidity of $55\pm 20/-40\%RH$.

2. 測量儀表和設備 / Measuring instruments and devices

2.1 電壓表：測量電壓的儀器準確度應不低於 0.25%，精密度應不低於最後一位有效數值的 50%，內阻應不小於 $1M\Omega$ 。

Voltmeter : The accuracy of the measuring equipment shall be $\leq 0.25\%$ and the precision shall be $\leq 50\%$ of the value of the last significant digit. The internal resistance of the measuring instrument shall be $\geq 1M\Omega$.

2.2 負載電阻：負載電阻包括所有外電路，其容許誤差為 $\pm 0.5\%$ 以內。

Load resistance : The load resistance shall include all of the external circuit, and its allowance shall be within $\pm 0.5\%$.

2.3 游標卡尺：游標卡尺應具有 0.05mm 或更高的精確度。

Caliper : The caliper shall be the one having precision of 0.05 millimeters or the one having the same or superior precision to this.

3. 測試方法 Test method

3.1 規格尺寸：用游標卡尺進行測量

Dimensions : Measurements shall be made by use of the calipers.

3.2 外型：用目視法檢查

Appearance : Examination shall be carried out by visual inspection.

3.3 空載電壓：在樣品放電開始之前，用電壓表進行測量。

Open-circuit voltage: Measurements shall be carried out before the start of discharge of the sample by use of the voltmeter.

3.4 放電壽命 Service output

放電開始時間：置於 $20\pm 2^{\circ}\text{C}$ 溫度條件下不少於 8 小時後。

Discharge start time: After leaving in an atmosphere at a temperature of $20\pm 2^{\circ}\text{C}$ for at least 8 hours or more.

放電溫度濕度： $20\pm 2^{\circ}\text{C}$ ， $55\pm 20/-40\%RH$ 。

Discharge temperature and humidity: $20\pm 2^{\circ}\text{C}$ ， $55\pm 20/-40\%RH$.

放電方法：按第 3 頁之 6.2 條，但是，在 7 天中要有 5 天以上進行放電，並且當放電為一天兩次時，兩次放電之間應相隔 4 小時。

Discharge method : As defined in 6.2. However discharge shall be effected for more than 5 days during 7 days and when discharge is made twice a day , an interval of 4 hours shall be elapsed between two discharges.

放電終止：閉路電壓已降到終止電壓(規定於第 3 頁之 6.2 條中)以下的那一瞬間。

Discharge end-point : The instant when the closed-circuit voltage has reached below the end-point voltage (as defined in 6.2, Page 3).

鋅錳干電池 Zinc Chloride Dry Battery SUM4/EXTRA

3.5 過放抗漏液 Overdischarge electrolyte leakage resistance

按以下條件進行試驗

The following conditions shall be adopted for the test

- (a) 放電開始: 置於 $20\pm 2^{\circ}\text{C}$ 溫度條件下至少 8 小時之後

Discharge start point: After keeping at the temperature of $20\pm 2^{\circ}\text{C}$ for at least 8 hours or more

- (b) 試驗溫度及濕度 : $20\pm 2^{\circ}\text{C}$, $55\pm 20/-40\%RH$

Test temperature and humidity: $20\pm 2^{\circ}\text{C}$, $55\pm 20/-40\%RH$

- (c) 負載電阻 : 15Ω

Load resistance : 15Ω

- (d) 試驗方法: 連續放電 48 小時

Test method : Continuous discharge for 48hours

3.6 高溫抗漏液 High temperature electrolyte leakage resistance

按以下條件進行試驗

The following conditions shall be adopted for the test

- (a) 試驗溫度及濕度: $45\pm 2^{\circ}\text{C}$, $\leq 70\%RH$.

Test temperature and humidity: $45\pm 2^{\circ}\text{C}$, below 70%

- (b) 試驗時間: 30 days

Test period : 30 days

- (c) 試驗方法: 靜止擺放

Test method : Leave to stand still.

鋅錳干電池 Zinc Chloride Dry Battery SUM4/EXTRA

附錄 2 : 放電特性

Appendix 2: Discharge characteristics

標準放電曲線:

STANDARD DISCHARGE CURVE

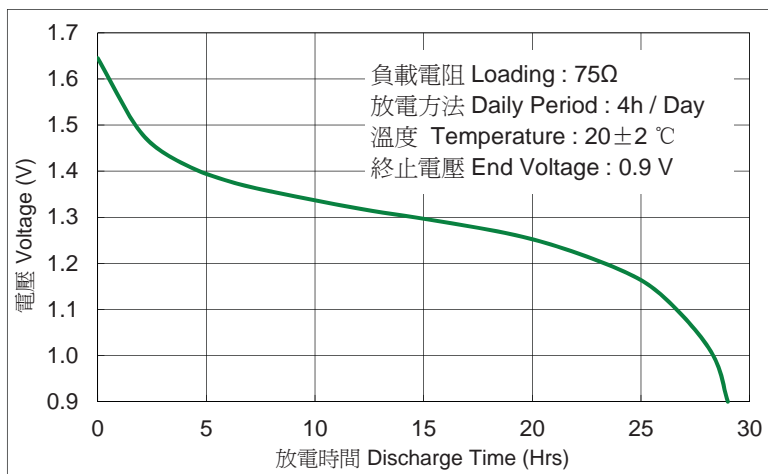
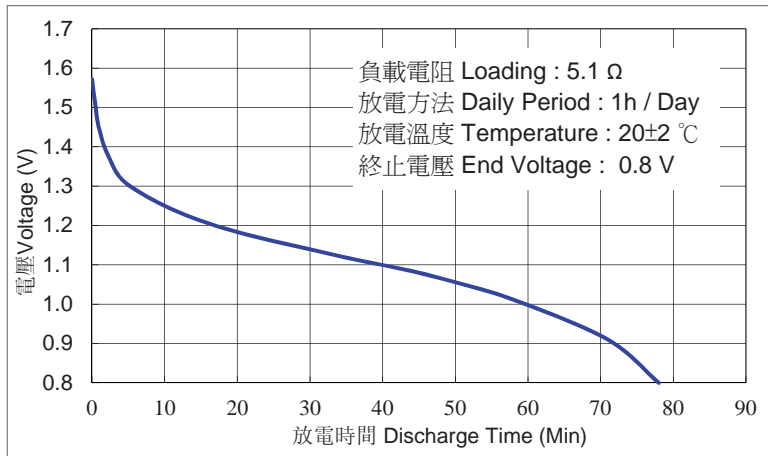

溫度特性(以不同電阻連續放電):

TEMPERATURE CHARACTERISTICS:

(Discharge continuously at various resistance)

