

Tenergy 14.8V 2200mAh Lithium Ion Battery with PCB

Product Name:	Tenergy Lithium Ion Battery Pack	
Product Number:	31021	
Battery Size:	14.8V/2200mAh	
Battery Chemistry:	Lithium Ion Rechargeable	
Dimension:	Max Length: 74mm	
	Max Width: 72mm	
	Max Thickness: 18mm	

1. Scope

This specification is applied to the reference battery in this Specification and manufactured by Tenergy Corp.

2. Product Specification

Table 1

No.	Item	General Parameter		Remark
		Typical		
1	Rated Capacity	2200mAh		Standard discharge (0.2C) after Standard charge
		2150mAh		
2	Nominal Voltage	14.8V		Mean Operation Voltage
3	Voltage at end of Discharge	12V		Discharge Cut-off Voltage
4	Charging Voltage	16.8±0.03V		



Tenergy Corporation

436 Kato Terrace
 Fremont CA 94539 USA
 Tel: 510-687-0388 Fax: 510-687-0328
www.TenergyBattery.com email: sales@tenergybattery.com

5	Internal Impedance	≤400mΩ	Internal resistance measured at AC 1KHz after 50% charge The measure must uses the new batteries that within one week after shipment and cycles less than 5 times
6	Standard charge	Constant Current 0.2C Constant Voltage 16.8V 0.01 C cut-off	
7	Standard discharge	Constant current 0.2 C end voltage12V	
8	Fast charge	Constant Current 0.5C Constant Voltage 16.8V 0.01 C cut-off	
9	Fast discharge	Constant current 1C end voltage 12V	
10	Maximum Continuous Charge Current	1 C	
11	Maximum Continuous Discharge Current	1C	
12	Operation Temperature Range	Charge: 0~45°C	60±25%R.H. Bare Cell
		Discharge: -20~60°C	
13	Storage Temperature Range	Less than 1 year: -20~25°C	60±25%R.H. at the shipment state
		less than 3 months: -20~40°C	
14	Weight	Approx: 226g	

3. Performance and Test Conditions

3.1 Standard Test Conditions

Specifications and data are subject to change without notice. Contact Tenergy for latest information.
 ©2009 Tenergy Corporation. All rights reserved.

Test should be conducted with new batteries within one week after shipment from our factory and the cells shall not be cycled more than five times before the test. Unless otherwise specified, test and measurement shall be done under temperature of $20 \pm 5^{\circ}\text{C}$ and relative humidity of 45~85%. If it is judged that the test results are not affected by such conditions, the tests may be conducted at temperature $15 \sim 30^{\circ}\text{C}$ and humidity 25~85%RH.

3.2 Measuring Instrument or Apparatus

3.2.1 Dimension Measuring Instrument

The dimension measurement shall be implemented by instruments with equal or more precision scale of 0.01mm.

3.2.2 Voltmeter

Standard class specified in the national standard or more sensitive class having inner impedance more than $10\text{k}\Omega/\text{V}$.

3.2.3 Ammeter

Standard class specified in the national standard or more sensitive class. Total external resistance including ammeter and wire is less than 0.01Ω .

3.2.4 Impedance Meter

Impedance shall be measured by a sinusoidal alternating current method (1kHz LCR meter).

3.3 Standard Charge\Discharge

3.3.1 Standard Charge : Test procedure and its criteria are referred as follows:

Charging shall consist of charging at a 0.2C constant current rate until the cell reaches 16.8V. The cell shall then be charged at constant voltage of 16.8 volts while tapering the charge current. Charging shall be terminated when the charging current has tapered to 0.01 C. The cell shall demonstrate no permanent degradation when charged between 0°C and 45°C .

3.3.2 Standard Discharge

Cells shall be discharged at a constant current of 0.2 C5A to 12 volts @ $20^{\circ} \pm 5\text{C}$

3.3.3 If not otherwise specified, the rest time between Charge and Discharge is 30min.

3.4 Appearance



There shall be no such defect as flaw, crack, rust, leakage, which may adversely affect commercial value of battery.

3.5 Initial Performance Test

Table 2

Item	Test Method and Condition	Requirements
(1) Open-Circuit Voltage	The open-circuit voltage shall be measured within 24 hours after standard charge	≥16.2V
(2) Internal impedance	Internal resistance measured at AC 1KHz after 50% charge	≤400mΩ
(3) Minimal Rated Capacity	The capacity on 0.2C discharge till the voltage tapered to 12V shall be measured after rested for 30min then finish standard charge	Discharge Capacity ≥2150mAh

3.6 Temperature Dependence of discharge capacity

Cells shall be charged per 3.3.1 and discharged @0.2 C to 12 volts, except to be discharged at temperatures per Table 3. Cells shall be stored for 3 hours at the test temperature prior to discharging and then shall be discharged at the test temperature. The capacity of a cell at each temperature shall be compared to the capacity achieved at 23 °C and the percentage shall be calculated. Each cell shall meet or exceed the requirements of Table 3.

Table 3

Discharge Temperature	-10°C	0°C	23°C	60°C
Discharge Capacity (0.2 C)	50%	80%	100%	95%

3.7 Cycle Life and Leakage-Proof

Table 4

No.	Item	Criteria	Test Conditions
-----	------	----------	-----------------

1	Cycle Life	Higher than 70% of the Initial Capacities of the Cells	Carry out 300cycle Charging/Discharging in the below condition. ◆ Charge: Standard Charge, per 3.3.1 ◆ Discharge:0.5 C to 12 V ◆ Rest Time between charge/discharge: 30min. ◆ Temperature:20±5°C
2	Leakage-Proof	No leakage (visual inspection)	After full charge with standard charge, store at 60±3°C, 60±10%RH for 1 month.

4. Mechanical characteristics and Safety Test

Table 5

(Mechanical characteristics)

No.	Items	Test Method and Condition	Criteria
1	Vibration Test	After standard charging, fixed the cell to vibration table and subjected to vibration cycling that the frequency is to be varied at the rate of 1Hz per minute between 10Hz an 55Hz, the excursion of the vibration is 1.6mm. The cell shall be vibrated for 30 minutes per axis of XYZ axes.	No leakage No fire
2	Drop Test	The cell is to be dropped from a height of 1 meter twice onto concrete ground.	No explosion, No fire, no leakage.

Table 6

(Safety Test)

Item	Battery Condition	Test Method	Requirements



Crush	Fresh, Fully charged	Crush between two flat plates. Applied force is about 13kN(1.72Mpa) for 30min.	No explosion, No fire
Short Circuit	Fresh, Fully charged	Each test sample battery, in turn, is to be short-circuited by connecting the (+) and (-) terminals of the battery with a Cu wire having a maximum resistance load of 0.1Ω. Tests are to be conducted at room temperature(20±2°C).	No explosion, No fire The Temperature of the surface of the Cells are lower than 150°C
Short Circuit	Fresh, Fully charged	Each test sample battery, in turn, is to be short-circuited by connecting the (+) and (-) terminals of the battery with a Cu wire having a maximum resistance load of 0.1Ω. Tests are to be conducted at temperature(60±2°C)	No explosion, No fire The Temperature of the surface of the Cells are lower than 150°C
Impact	Fresh, Fully charged	A 56mm diameter bar is inlayed into the bottom of a 10kg weight. And the weight is to be dropped from a height of 1m onto a sample battery and then the bar will be across the center of the sample.	No explosion, No fire
Forced Discharge	Fresh, Fully charged	Discharge at a current of 1 C for 2.5h.	No explosion, No fire
Nail Pricking	Fresh, Fully charged	Prick through the sample battery with a nail having a diameter of 3mm and remain 2h.	No explosion, No fire

5. PCB Data sheet

The PCB will control each series-wound power system independently.



Electrical characteristics $T_{opt}=25^{\circ}C$

Item	Content	Criterion
Over charge Protection	Over charge detection voltage	4.35±0.025V
	Over charge release voltage	4.15±0.025V
Over discharge protection	Over discharge detection voltage	2.4±0.08V
	Over discharge release voltage	3.0±0.1V
	Rated operational current	≤5A
Over current protection	Over current detection current	6.2A
	Release condition	Cut load
	Detection delay time	8.0~16.0ms
Short protection	Detection condition	Exterior short circuit
	Release condition	Cut short circuit
Interior resistance	Main loop electrify resistance	$V_C=4.2V$; $R_{DS} \leq 60m\Omega$
Current consumption	Current consume in normal operation	35μA Max
(L*W*H)	50*16*1.1mm	

RG-L34S BOM

序号	物料名称	规格/型号	封装	位置/代号	数量	备注
1	贴片电阻	0R ±5%	0603	R5	1	
2	贴片电阻	1K ±5%	0603	R15, R8, R6, R3, R11, R9, R10, R7	8	
3	贴片电阻	1M ±5%	0603	R14	1	
4	贴片电阻	5.1K ±5%	0603	R12, R13	2	
5	贴片电阻	51R ±5%	0603	R4	1	
6	贴片电阻	0.02R 1W ±5%	2512	R0, R01	2	
7	贴片电容	0.1uF/50V ±20%	0603	C8, C7, C6, C4, C3, C2, C1	7	
8	贴片电容	2.2uF/50V ±20%	0805	C5	1	
9	IC	8254AAF	TSSOP-16	U1	1	
10	MOS	FSS134	S0-8	U2, U3, U4, U5	4	
11	PCB	RG-L34S	50*16*1.1 mm		1	
13	备注: R3, R10贴1K. R5, R7不贴					

Application Circuit

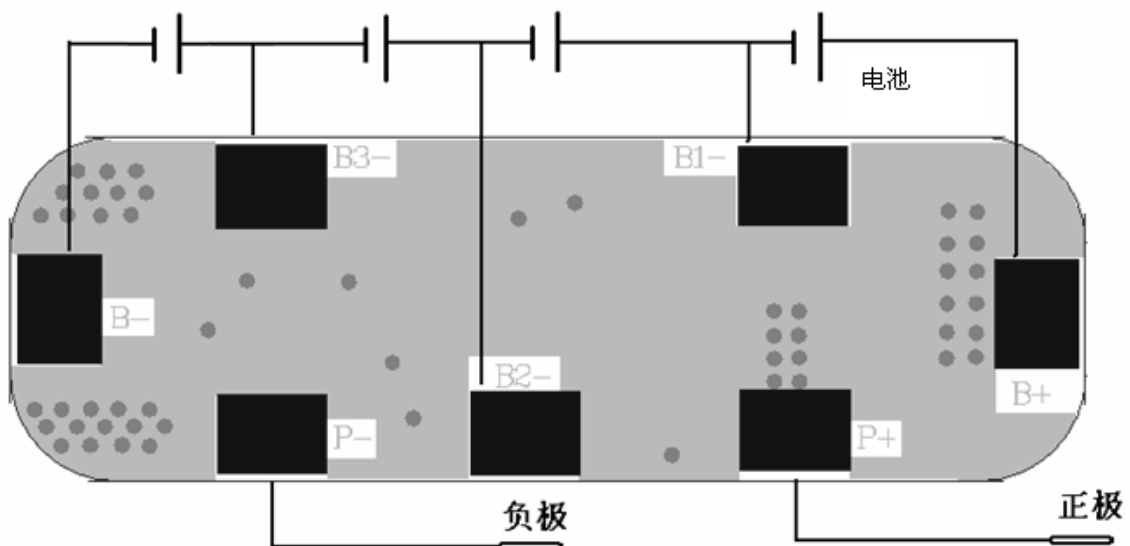
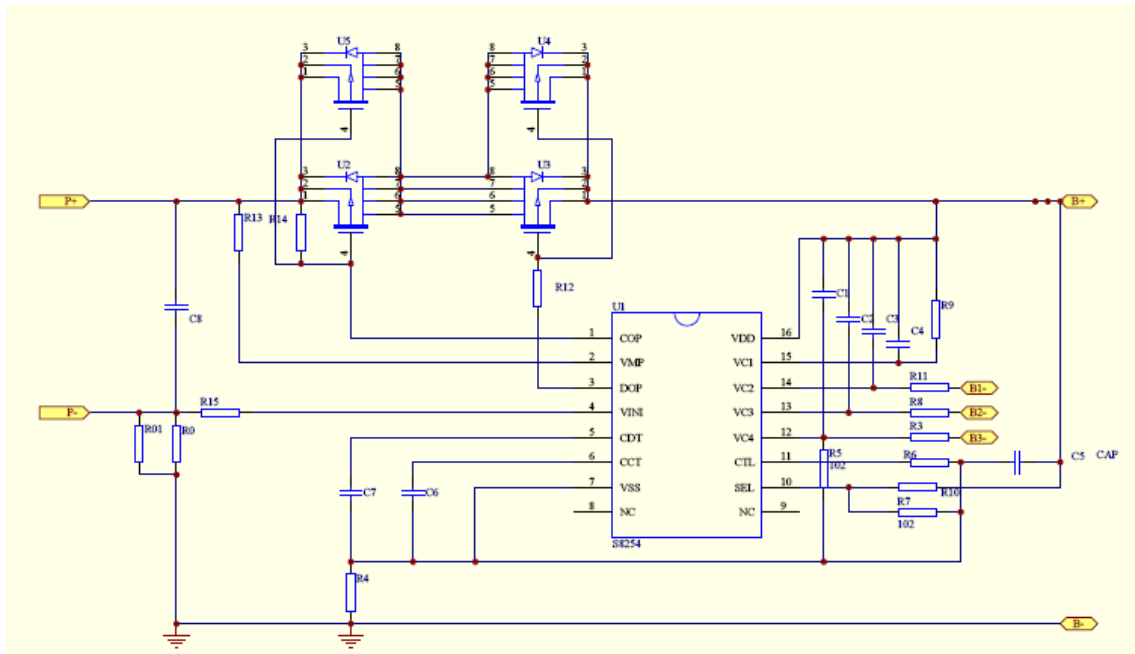



Tenergy Corporation

436 Kato Terrace
Fremont CA 94539 USA

Tel: 510-687-0388 Fax: 510-687-0328

www.TenergyBattery.com email: sales@tenergybattery.com

Terminal explanations

- 1、 B+: Connected to the forth battey's positive terminal
- 2、 B1-: Connected to the frist battey's positive terminal
- 3、 B2-: Connected to second the battey's positive terminal
- 4、 B3-: Connected to the third battey's positive terminal
- 5、 B-: Connected to the first battey's negative terminal
- 6、 P+: Connected to the battey's output or the charger's positive terminal
- 7、 P-: Connected to the battey's output or the charger's negative terminal